

Designated by Government
to issue
European Technical
Approvals

NATURALIGHT ROOFLIGHTS AND UPSTANDS

Lucarne
Dachoberlicht

Product



• THIS CERTIFICATE RELATES TO NATURALIGHT ROOFLIGHTS AND UPSTANDS.

- The rooflights and upstands are for use on flat roofs of domestic and commercial buildings, to provide natural light and ventilation.
- It is essential that the rooflights and upstands are installed and used in accordance with the conditions set out in the Design Data and Installation parts of this Certificate.

These Front Sheets must be read in conjunction with the accompanying Detail Sheets, which provide information specific to particular rooflights and upstands.

Regulations — Detail Sheet 1

1 The Building Regulations 2000 (as amended) (England and Wales)

 The Secretary of State has agreed with the British Board of Agrément the requirements of the Building Regulations to which plastic rooflights can contribute in achieving compliance. In the opinion of the BBA, NaturaLight Rooflights and Upstands, if used in accordance with the provisions of this Certificate, will meet or contribute to meeting the relevant requirements.

Requirement: A1	Loading
Comment:	When installed in accordance with the provisions of this Certificate, the products will have sufficient strength and stiffness to sustain the design load. See the tinted areas of the <i>Strength and stability</i> section of these Front Sheets and the accompanying Detail Sheets.
Requirement: B2(1)	Internal fire spread (linings)
Comment:	The polycarbonate sheets used in the rooflights can be classified as Tp(a) rigid material. See the tinted areas in the <i>Behaviour in relation to fire</i> section of these Front Sheets.
Requirement: B4(2)	External fire spread
Comment:	The polycarbonate sheets used in the rooflights can be taken as classified Tp(a) rigid material. See the tinted areas in the <i>Behaviour in relation to fire</i> section of these Front Sheets.

Requirement:	C2(b)(c)	Resistance to moisture
Comment:		When installed in accordance with this Certificate, the rooflights will not adversely affect the resistance of the roof to the passage of moisture. See the tinted areas in the <i>Weathertightness</i> section of these Front Sheets. Ventilators incorporated in the upstands will provide airflow to alleviate surface condensation in the rooflights. See the tinted areas in the <i>Condensation risk</i> section of these Front Sheets.
Requirement:	F1	Means of ventilation
Comment:		Opening rooflights and, when fitted, ventilators incorporated in the upstands can meet or contribute to meeting the Requirement. See the Ventilation section of these Front Sheets.
Requirement:	L1(a)(i)	Conservation of fuel and power
Comment:		The U values of some rooflights and upstands exceed the limiting U values given in Approved Documents. See the tinted areas in the <i>Thermal insulation</i> section of these Front Sheets. The products can contribute to daylighting and solar heat gain. See the tinted areas in the <i>Light and solar transmittance</i> section of these Front sheets.
Requirement:	Regulation 7	Materials and workmanship
Comment:		The products are acceptable when used in accordance with this Certificate. See the tinted area in the <i>Durability</i> section of these Front Sheets.

2 The Building (Scotland) Regulations 2004 (as amended)



In the opinion of the BBA, NaturalLight Rooflights and Upstands, if used in accordance with the provisions of this Certificate, will satisfy or contribute to satisfying the various Regulations and related Mandatory Standards as listed below.

Regulation:	8	Fitness and durability of materials and workmanship
Regulation:	8(1)	Fitness and durability of materials and workmanship
Comment:		The products can contribute to a construction satisfying this Regulation. See the tinted area in the <i>Durability</i> section of these Front Sheets and the <i>Installation</i> part of the accompanying Detail Sheets.
Regulation:	8(2)	Fitness and durability of materials and workmanship
Comment:		The products can contribute to a construction satisfying this Regulation. See the tinted area in the <i>Durability</i> section of these Front Sheets.
Regulation:	9	Building standards – construction
Standard:	1.1(b)	Structure
Comment:		When used in accordance with the provisions of this Certificate, the products will have sufficient strength and stiffness to sustain design loads, with reference to clause 1.1.1 ⁽¹⁾⁽²⁾ . See the tinted areas of the <i>Strength and stability</i> section of these Front Sheets and the accompanying Detail Sheets.
Standard:	2.5	Internal linings
Comment:		The polycarbonate sheets used in the rooflights can be classified as Tp(a) rigid material, with reference to clauses 2.5.4 ⁽¹⁾⁽²⁾ and 2.5.6 ⁽¹⁾⁽²⁾ . See the tinted areas of the <i>Behaviour in relation to fire</i> section of these Front Sheets.
Standard:	2.8	Spread from neighbouring buildings
Comment:		The polycarbonate sheets used externally in the rooflights have been assessed as 'low vulnerability', with reference to clause 2.8.2 ⁽¹⁾⁽²⁾ . See the tinted areas in the <i>Behaviour in relation to fire</i> section of these Front Sheets.
Standard:	3.10	Precipitation
Comment:		When installed in accordance with the provisions stated in this Certificate, the products will not adversely affect the resistance of the roof to the passage of moisture, with reference to clause 3.10.7 ⁽¹⁾⁽²⁾ . See the tinted areas in the <i>Weathertightness</i> section of these Front Sheets.
Standard:	3.14	Ventilation
Comment:		Opening rooflights and, when fitted, ventilators incorporated in the upstands can meet or contribute to meeting this Standard, with reference to clauses 3.14.2 ⁽¹⁾⁽²⁾ and 3.14.3 ⁽¹⁾⁽²⁾ . See the tinted areas in the <i>Ventilation</i> section of these Front Sheets.
Standard:	3.15	Condensation
Comment:		The risk of surface condensation will depend on the environmental conditions. When fitted, ventilators incorporated in the upstands will provide airflow to alleviate surface condensation on the rooflights, with reference to clause 3.15.4 ⁽¹⁾ . See the tinted areas in the <i>Condensation risk</i> section of these Front Sheets.

Standard:	3.16	Natural lighting
Comment:		In calculating the contribution of the system to natural lighting, with reference to clauses 3.16.1 ⁽¹⁾ and 3.16.3 ⁽¹⁾ to this Standard, the area of glazing given in the Tables in the <i>Thermal properties</i> section of the relevant accompanying Detail Sheets can be used.
Standard:	4.8(c)	Danger from accidents
Comment:		The provisions described in clauses 4.8.3 ⁽¹⁾⁽²⁾ to this Standard regarding the safe cleaning of rooflights, must be taken into account.
Standard:	4.8(e)	Danger from accidents
Comment:		Manual wormgear, when fitted, can meet or contribute to meeting this Standard, with reference to clause 4.8.6 ⁽²⁾ .
Standard:	6.1(b)	Carbon dioxide emissions
Standard:	6.2	Building insulation envelope
Comment:		With reference to clauses 6.1.1 ⁽¹⁾ , 6.1.2 ⁽¹⁾⁽²⁾ , 6.1.3 ⁽²⁾ , 6.2.1 ⁽¹⁾⁽²⁾ , 6.2.7 ⁽¹⁾ , 6.2.8 ⁽²⁾ , 6.2.9 ⁽¹⁾ and 6.2.10 ⁽²⁾ , see the relevant tinted areas in the <i>Thermal insulation</i> and <i>Light and solar transmittance</i> sections of these Front Sheets. (1) Technical Handbook (Domestic). (2) Technical Handbook (Non-Domestic).

3 The Building Regulations (Northern Ireland) 2000 (as amended)



In the opinion of the BBA, NaturalLight Rooflights and Upstands, if used in accordance with the provisions of this Certificate, will satisfy or contribute to satisfying the various Building Regulations as listed below.

Regulation:	B2	Fitness of materials and workmanship
Comment:		The products are acceptable when used in accordance with this Certificate. See the tinted area in the <i>Durability</i> section of these Front Sheets.
Regulation:	C4(b)	Resistance to ground moisture and weather
Comment:		When installed in accordance with the provisions stated in this Certificate, the products will not adversely affect the resistance of the roof to the passage of moisture. See the tinted areas in the <i>Weather-tightness</i> section of these Front Sheets.
Regulation:	D1	Stability
Comment:		When installed in accordance with the provisions of this Certificate, the products will have sufficient strength and stiffness to sustain the design load. See the tinted areas of the <i>Strength and stability</i> section of these Front Sheets and the Detail Sheets.
Regulation:	E4(1)	Internal fire spread — Structure
Comment:		The polycarbonate sheets used in the rooflights can be classified as Tp(a) rigid material. See the tinted areas in the <i>Behaviour in relation to fire</i> section of these Front Sheets.
Regulation:	E5(b)	External fire spread
Comment:		The polycarbonate sheets used in the rooflights can be classified as Tp(a) rigid material. See the tinted areas in the <i>Behaviour in relation to fire</i> section of these Front Sheets.
Regulation:	F2(a)(i)	Conservation measures
Regulation:	F3(2)	Target carbon dioxide Emissions Rate
Comment:		The U value of some rooflights and upstands exceed the limiting U values given in the Technical Booklets. See the relevant tinted areas in the <i>Thermal insulation</i> and <i>Light and solar transmittance</i> sections of these Front Sheets.
Regulation:	K2	Means of ventilation
Comment:		Opening rooflights and, when fitted, ventilators incorporated in the upstands can meet or contribute to meet the requirements of this Regulation. See the <i>Ventilation</i> section of these Front Sheets.

4 Construction (Design and Management) Regulations 2007

Construction (Design and Management) Regulations (Northern Ireland) 2007

Information in this Certificate may assist the client, CDM co-ordinator, designer and contractors to address their obligations under these Regulations.

See section: 6 Delivery and site handling (6.1, 6.3 and 6.5) of these Front Sheets.

Technical Specification

5 Description

Rooflights

5.1 Naturalight polycarbonate rooflights are fully described in the accompanying Detail Sheets.

Upstands

5.2 The Naturalight upstands are fully described in the accompanying Detail Sheets.

5.3 Quality control checks on the units include:

- dimensional accuracy
- visual inspection
- thickness of polycarbonate
- quality of finishes.

6 Delivery and site handling

6.1 The Certificate holder's recommendations for site handling and installation are provided with each delivery.

6.2 The rooflights and upstands are delivered to site ready assembled or in kit form, wrapped in bubble wrap protective sheet ready for installation. Each rooflight carries a sticker bearing the company's mark and the job identification mark.

6.3 Smaller units may be manhandled to roof level but larger units will require cranes.

6.4 If the rooflights are to be stored on site they should be stacked on edge with an air gap between each rooflight on a dry, flat, level surface under cover away from direct sunlight. Rooflights must not be nested at any time.

6.5 Before installation the upstands should be laid on timber packers placed on a level surface to avoid damage to finishes and accessories.

6.6 When selecting means of access, eg use of scaffolding, the safety of operatives, occupants and passers-by during the period of installation should be considered.

Design Data

7 General

7.1 Naturalight Rooflights and Upstands are suitable for use on the flat roofs of domestic or commercial buildings. Roofs should be designed in accordance with BS 6229 : 2003.

7.2 The plastic rooflights and upstands are suitable for most existing roofs but it is important that the roof is checked by a suitably-qualified person to ensure that the possible removal of roof supporting members will not cause any problems and that it can bear any possible additional loads imposed upon it by the installation of the products.

7.3 The plastic rooflights are suitable for replacing existing rooflights. The suitability of existing upstands must be checked and be replaced if necessary. The rooflights should not be used without an upstand. The use of upstands other than those described in the accompanying Detail Sheets is outside the scope of this Certificate.

8 Practicability of installation

The plastic rooflights and upstands are practicable to install using the methods and procedures within this Certificate and in accordance with the recommendations given in the Certificate holder's installation guide.

9 Strength and stability



9.1 The products can be selected to have adequate resistance to wind loads calculated in accordance with BS 6399-2 : 1997.

9.2 In tests, rooflights withstood an imposed load of 750 Nm^{-2} . The magnitude of the actual snow load imposed will depend upon a number of factors, such as height above sea level, geographical location, roof arrangement, type and configuration of rooflights. Therefore, it is recommended that BS 6399-3 : 1988 is used to calculate the actual snow load when the roof is used in situations where a load greater than 750 Nm^{-2} can be expected.

9.3 Details of the connections between the upstand and the roof must be entrusted to a suitably-qualified person. Guidance is available from the Certificate holder.

9.4 The polycarbonate rooflight material has a good resistance to impact from hard bodies, such as hailstones, or impacts due to vandalism. Tests on typical rooflight samples showed that an impact energy of 2.5 J did not cause damage when applied at various points of the rooflights.

9.5 Fixing the rooflight to the upstand is described in the *Installation* part of the accompanying Detail Sheets. Adequate resistance to wind uplift is achieved by this type of fixing.

9.6 The products have adequate resistance to soft-body impacts, such as a person falling against a rooflight. The results of tests for selected rooflights are given in the *Strength and stability* sections of the accompanying Detail sheets.

10 Weathertightness



10.1 When installed in accordance with the manufacturer's instructions and section 19 of these Front Sheets and sections 5 and 6 in the relevant Detail Sheets, the rooflights and upstands will provide a weatherproof construction.

10.2 Particular attention must be paid to the correct fitting of all components and to the detailing of sealants and roofing materials.

10.3 The installation of vents will affect the air permeability performance. The type of vent specified should take into account the prevailing weather conditions. For example, in locations when driving snow is likely, the selection of a closable vent is recommended.

11 Behaviour in relation to fire



11.1 The rigid, solid, 3 mm thick polycarbonate sheets used in the rooflights may be classified as Tp(a) rigid in accordance with the national Building Regulations:

England and Wales

Approved Document B, Volume 1 *Dwellings*, Appendix A, Sections 19 and 20 and Volume 2 *Buildings other than dwellings*, Appendix A, Sections 19 and 20

Scotland

Mandatory Standard 2.5, clause 2.5.4⁽¹⁾⁽²⁾

(1) Technical Handbook (Domestic).

(2) Technical Handbook (Non-Domestic).

Northern Ireland

Technical Booklet E, section 2.5.

11.2 The polycarbonate sheets have a Class 1Y surface as is defined in BS 476-7 : 1997.

11.3 Guidance on the limitations of use of these materials is given in the national Building Regulations:

England and Wales

Approved Document B, Volume 1 *Dwellings*, Section 10.6, Table 7 and Volume 2 *Buildings other than dwellings*, Section 14.6, Table 18

Scotland

Mandatory Standards 2.5, 2.8 and 2.9, clauses 2.5.6⁽¹⁾⁽²⁾, 2.8.1⁽¹⁾⁽²⁾ and 2.9.17⁽²⁾ respectively.

The rigid, solid, 3 mm thick polycarbonate sheets can be classified as 'low vulnerability' in accordance with Standard 2, Annex 2D⁽¹⁾ and Annex 2F⁽²⁾

(1) Technical Handbook (Domestic).

(2) Technical Handbook (Non-Domestic).

Northern Ireland

Technical Booklet E, Tables 2.2 and 4.8.

12 Light and solar transmittance

12.1 For design purposes, the approximate light and solar transmittance characteristics of new material at normal incidence is given in Table 1. These figures and the daylight opening areas given or directed in the *Thermal properties* section of the accompanying Detail Sheets may be used in SAP and SBEM⁽¹⁾ calculations.

(1) Further guidance is given in *Designing with rooflights* supporting the guidance given in Approved Documents L2A and L2B (issue 1, September 2006, published by NARM).

Table 1 Light and solar transmittance

	Light transmittance ⁽¹⁾	Solar transmittance (g _v) ⁽¹⁾
Single-skin	0.8	0.8
Double-skin	0.7	0.7
Triple-skin	0.5	0.5

(1) Default values taken from SBEM.



12.2 When showing compliance to the relevant Requirement or Regulation for Conservation of fuel and power (limiting the heat loss through the fabric of the building) of the national Building Regulations, by using the following method or calculation, the contribution from solar gain and the provision of daylight by rooflights can be assessed:

- Carbon Emissions Calculation Method (Scotland), or the Simplified Building Energy Model (SBEM)⁽¹⁾ (England and Wales and Northern Ireland) for buildings other than dwellings, or
- calculating the SAP Energy Rating of a dwelling.

(1) Further guidance is given in *Designing with rooflights* supporting the guidance given in Approved Documents L2A and L2B (issue 1, September 2006, published by NARM).

12.3 The methods outlined in CIBSE Guide A : 2006 *Environmental design*, Section 5.7 and 5.8 and Appendix 5 should be used if the total solar gain of the building incorporating the products presents a significant heat input.

13 Ventilation



If fitted, ventilators installed in pairs on opposite sides of the long edges of upstands types NLS 310, NLS 320, NLS 325 and NLS 330, will provide ventilation to the room below the rooflight. Additionally, the rooflights can be opened using manual wormgear. The ventilator openings can provide or contribute to providing the background ventilation (trickle ventilation) open area requirements given in the national Building Regulations:

England and Wales

Approved Document F, Tables 1.2 (a–d) are relevant for dwellings. The equivalent area of any background ventilator incorporated in the upstand should be determined at a 1 Pa pressure difference, using the appropriate test method given in Table 1.6 of the Approved Documents. Separate guidance for buildings other than dwellings is given in Tables 2.2 and 2.3

Scotland

Mandatory Standard 3.14, clauses 3.14.2⁽¹⁾⁽²⁾, 3.14.3⁽¹⁾⁽²⁾ and 3.14.5⁽¹⁾

(1) Technical Handbook (Domestic).

(2) Technical Handbook (Non-Domestic).

Northern Ireland

Technical Booklet K, Tables 2.1 and 2.2.

14 Thermal insulation



14.1 U values, based on the internal surface area for different combinations of rooflights and upstands, are given in the relevant Tables given in the accompanying Detail Sheets.

14.2 Any rooflight U value exceeding the limiting values in Table 2 do not comply with the requirements. When showing compliance, the U values and areas given in the relevant tables may be used to calculate the area-weighted U values for windows, rooflights and doors, which will need to be better than $2.2 \text{ Wm}^{-2}\text{K}^{-1}$.

Table 2 Limiting values

	Limiting U values ($\text{Wm}^{-2}\text{K}^{-1}$)	
	Double-skin	Triple-skin
England and Wales and Northern Ireland	3.8	3.6
Scotland	3.3	3.3

14.3 The thermal transmittance (U values) of the polycarbonate glazing skins of the rooflights according to BS EN 673 : 1998, when horizontal, are $3.2 \text{ Wm}^{-2}\text{K}^{-1}$ for the double-skin options and $2.0 \text{ Wm}^{-2}\text{K}^{-1}$ for the triple-skin options, (assuming an average 14 mm wide cavity between skins).

14.4 Rooflight assemblies are permeable to air at the junction between rooflight and upstand, particularly where an opening mechanism is present. Air permeability is beneficial for control of condensation but can also have an effect on thermal insulation properties. This may affect the airtightness of the building envelope.

15 Condensation risk



15.1 The risk of condensation forming on an internal surface of the rooflight is dependent on its temperature and the temperature and humidity of the adjacent air. The risk will be minimal when the rooflight's minimum surface temperature factor exceeds that shown in Table 3, for the relevant building type.

Table 3 Minimum temperature factors⁽¹⁾ to minimise the risk of surface condensation

Humidity Class	Building type	Temperature factors for 20°C internal temperature and humidity range in BS EN ISO 13788 : 2002, Figure A.1 (section 5.4)
1	Storage areas	≤ 0.20
2	Office, shops	0.21 – 0.40
3	Dwellings with low occupancy	0.41 – 0.57
4	Dwellings with high occupancy, sports halls, kitchens, canteens, buildings heated with unflued gas heaters	0.58 – 0.71
5	Special buildings, eg laundry, brewery, swimming pools	≥ 0.72

(1) The ratio of temperature drop between the internal rooflight surface and the external environment and the total temperature drop between internal and external environments.

15.2 Modelling of the rooflights in accordance with BS EN ISO 10211-1 : 1996 and BS EN ISO 10211-2 : 2001 indicates the minimum temperature factors shown in Table 4.

Table 4 Minimum temperature factors for NaturalLight rooflights

Construction	Minimum temperature factor
Aluminium upstand	0.34
Galvanized steel upstand	0.33
Aluminium upstand and aluminium opening frame	0.15
Galvanized steel upstand and galvanized opening frame	0.13
PVC-U upstand	0.35
PVC-U upstand with Securilight frame	0.36
PVC-U upstand and PVC-U opening frame	0.36
PVC-U upstand with PVC-U opening frame and Securilight	0.37

15.3 Where the temperature factors given in Table 4 are less than those given in Table 3, for the relevant activity, there is a risk of surface condensation forming. However, limited intermittent condensation, appearing initially on the upstand, will not be detrimental to the rooflight. By way of comparison, minimum temperature factors for typical PVC-U windows are between 0.50 and 0.65.

15.4 In all cases, the risk of surface condensation can be reduced by limiting activities which produce large amounts of moisture and providing means for adequate ventilation; in particular air flow from upstand mounted trickle ventilators, when fitted, can alleviate localised surface condensation.

16 Safety

16.1 If the rooflight is located on a roof which is generally accessible to the public, provision must be made to prevent people falling onto the glazed part (eg guard rails). If, as the result of an accidental fall, contact is made with the polycarbonate rooflight, the polycarbonate material shows good resistance to impact (see the *Strength and stability* sections of the accompanying Detail Sheets).

16.2 When subjected to normal atmospheric agents, movement of the structure, hygrothermal stresses, or vibrations, the polycarbonate rooflights will not collapse or result in falling debris that would cause injury to occupants or passers-by.

17 Maintenance

17.1 If damage occurs, the rooflights can be re-glazed and the fixings replaced, but these operations should be carried out using the materials recommended by the Certificate holder and approved by the BBA.

17.2 Cleaning of the rooflights should be carried out using water containing household detergent. To avoid scratching of the surface, only soft cloths should be used when cleaning.

17.3 Under no circumstances should anyone venture onto a polycarbonate rooflight. For maintenance purposes special precautions must be taken to prevent the possibility of falling through the polycarbonate rooflight, even though the rooflight may support such a load.

18 Durability



Available test data and knowledge of the material suggest that the products, when installed in accordance with this Certificate, should have a life of at least 10 years for the polycarbonate material and painted upstands in most non-corrosive environments. Minor changes in surface appearance and a reduction in light transmission may occur during this period.

Installation

19 General

19.1 Installation of the NaturaLight Rooflights and Upstands should be carried out in accordance with the Certificate holder's installation instructions (see the *Installation* part of the accompanying Detail Sheets).

19.2 Where an adaptor upstand is specified, supporting structures must have a suitable sealant applied to them before the base flange is positioned. The standard upstands do not require sealing as they are protected by the roof covering.

19.3 When selecting means of access (eg by use of scaffolding), the safety of operatives, occupants and passers-by during the period of installation should be considered.

Bibliography

BS 476-7 : 1997 *Fire tests on building materials and structures — Method of test to determine the classification of the surface spread of flame of products*

BS 6229 : 2003 *Flat roofs with continuously supported coverings — Code of practice*

BS 6399-2 : 1997 *Loading for buildings — Code of practice for wind loads*

BS 6399-3 : 1988 *Loading for buildings — Code of practice for imposed roof loads*

BS EN 673 : 1998 *Glass in building — Determination of thermal transmittance (U value) — Calculation method*

BS EN ISO 10211-1 : 1996 *Thermal bridges in building construction — Heat flows and surface temperatures — General calculation methods*

BS EN ISO 10211-2 : 2001 *Thermal bridges in building construction — Calculation of heat flows and surface temperatures — Linear thermal bridges*

BS EN ISO 13788 : 2002 *Hygrothermal performance of building components and building elements — Internal surface temperature to avoid critical surface humidity and interstitial condensation — Calculation methods*

Conditions of Certification

20 Conditions

20.1 This Certificate:

- relates only to the product/system that is named and described on the front page
- is granted only to the company, firm or person named on the front page — no other company, firm or person may hold or claim any entitlement to this Certificate
- is valid only within the UK
- has to be read, considered and used as a whole document — it may be misleading and will be incomplete to be selective
- is copyright of the BBA
- is subject to English law.

20.2 References in this Certificate to any Act of Parliament, Statutory Instrument, Directive or Regulation of the European Union, British, European or International Standard, Code of Practice, manufacturers' instructions or similar publication, are references to such publication in the form in which it was current at the date of this Certificate.

20.3 This Certificate will remain valid for an unlimited period provided that the product/system and the manufacture and/or fabrication including all related and relevant processes thereof:

- are maintained at or above the levels which have been assessed and found to be satisfactory by the BBA
- continue to be checked as and when deemed appropriate by the BBA under arrangements that it will determine
- are reviewed by the BBA as and when it considers appropriate.

20.4 In granting this Certificate, the BBA is not responsible for:

- the presence or absence of any patent, intellectual property or similar rights subsisting in the product/system or any other product/system
- the right of the Certificate holder to manufacture, supply, install, maintain or market the product/system
- individual installations of the product/system, including the nature, design, methods and workmanship of or related to the installation
- the actual works in which the product/system is installed, used and maintained, including the nature, design, methods and workmanship of such works.

20.5 Any information relating to the manufacture, supply, installation, use and maintenance of this product/system which is contained or referred to in this Certificate is the minimum required to be met when the product/system is manufactured, supplied, installed, used and maintained. It does not purport in any way to restate the requirements of the Health & Safety at Work etc Act 1974, or of any other statutory, common law or other duty which may exist at the date of this Certificate; nor is conformity with such information to be taken as satisfying the requirements of the 1974 Act or of any statutory, common law or other duty of care. In granting this Certificate, the BBA does not accept responsibility to any person or body for any loss or damage, including personal injury, arising as a direct or indirect result of the manufacture, supply, installation, use and maintenance of this product/system.



In the opinion of the British Board of Agrément, NaturaLight Rooflights and Upstands are fit for their intended use provided they are installed, used and maintained as set out in this Certificate. Certificate No 06/4344 is accordingly awarded to NaturaLight Systems Limited.

On behalf of the British Board of Agrément

Date of issue: 21st November 2007

Chief Executive

Product

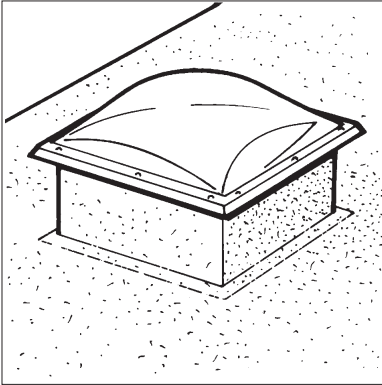

- THIS DETAIL SHEET RELATES TO THE NATURALIGHT FIXED OR OPENING INDIVIDUAL ROOFLIGHTS AND UPSTANDS.
- The opening mechanism is operated by manual wormgear.

This Detail Sheet must be read in conjunction with the Front Sheets, which give the product's position regarding the Building Regulations, general information relating to the system, and the Conditions of Certification.

Technical Specification

1 Description

1.1 The skins of The Naturalight Fixed or Opening Individual Rooflights and Upstands are designed and thermoformed from 3 mm minimum thick polycarbonate sheets, both sides coated with UV protection film, for use in the exposure conditions described in this Detail Sheet.

1.2 The polycarbonate rooflights are available as double- or triple-skin, in clear, smooth finish and are fixed through factory-drilled holes onto the upstands. The polycarbonate glazing is available

in a curved dome or a pyramid profile. Double- and triple-skin rooflights incorporate a double-sided adhesive PVC foam tape between skins. They are available in the styles and sizes listed in Table 1 and shown in Figure 1. Opening rooflights (with manual wormgear) are supplied pre-assembled. Fixed rooflights can be supplied pre-assembled or separately.

Table 1 Sizes and styles of rooflights

Rooflight type	Size range (m)
Square domed or pyramidal	0.6 x 0.6 to 1.8 x 1.8
Rectangular domed or pyramidal	0.6 to 1.8 m wide by 0.9 to 2.4 long

Figure 1 Naturalight individual rooflights

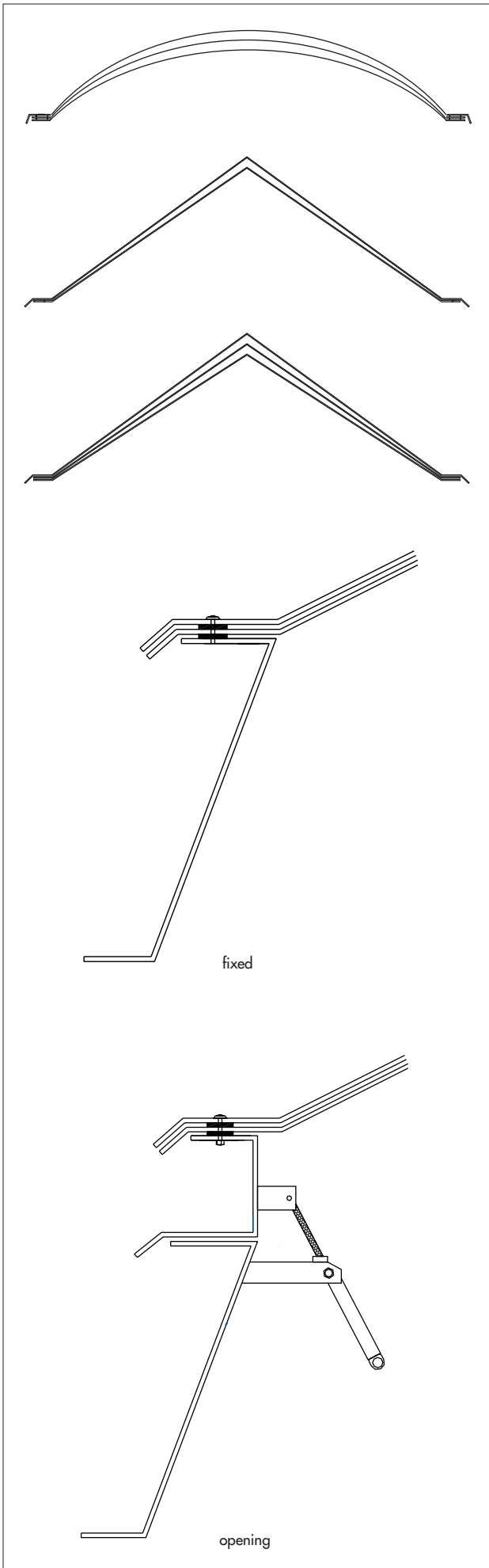

1.3 The upstands, adaptor upstands and opening frames are available in two materials: galvanized steel and aluminium and have a white, powder-coated finish. Types of upstands are listed in Table 2 and shown in Figure 2.

Figure 2 Typical Naturalight upstands

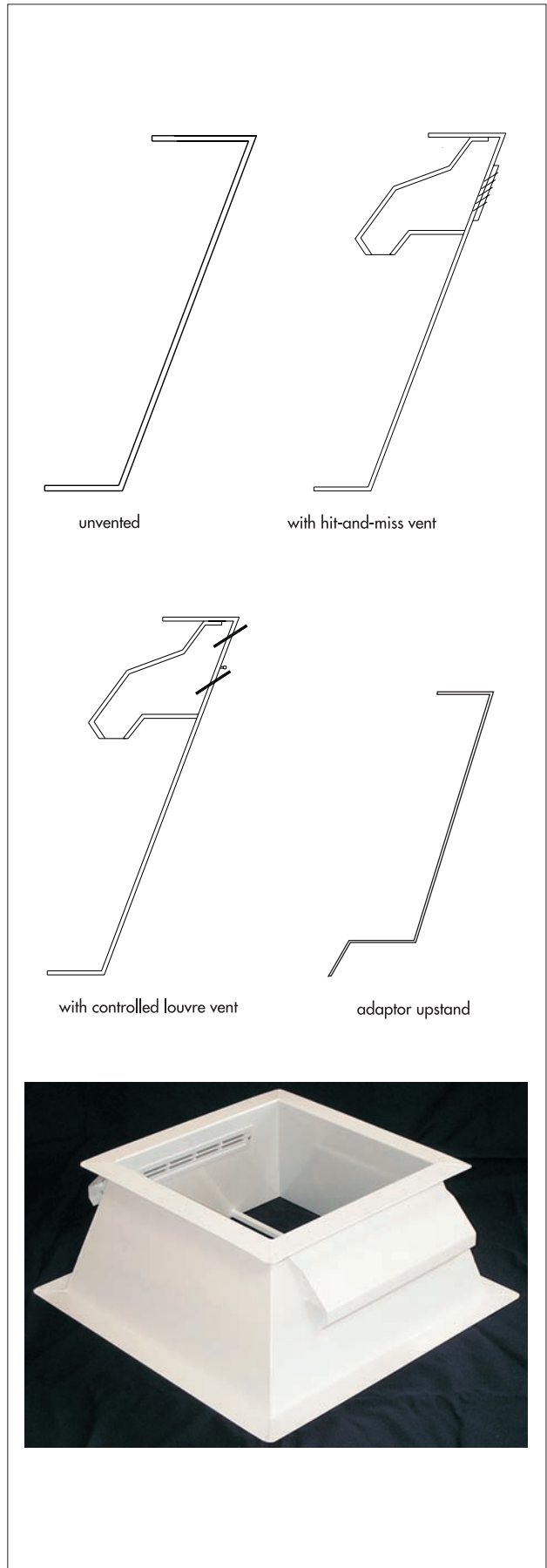

Table 2 Naturalight upstands

Type	Upstands for individual rooflights
Unvented	NLS 300
Permanent ventilation	NLS 310
Hit-and-miss	NLS 320
Hit-and-miss slimline	NLS 325
Controlled louvre	NLS 330
Controlled louvre 50%	NLS 360

1.4 Cork board insulation (10 mm thick) is available for aluminium and galvanized steel upstands.

1.5 Upstands may be unvented or may incorporate permanent vents, hit-and-miss vents or controlled louvres (see Table 2 and Figure 2). The height of galvanized steel and aluminium unvented upstands is 225 mm and that of the vented types 225 mm to the underside of the vent. Additional height can be provided to metal upstands to compensate for fitting below deck, or exceptional depth of insulation and screed.

1.6 The full specifications and drawings for the materials and components covered by this Detail Sheet are retained by the BBA.

1.7 Rooflights can be supplied separately, for assembling on site, pre-assembled onto the upstands, or pre-assembled with Securilight, frame (a welded aluminium framework) around the edge of the rooflight (see Figure 4 and section 4). In addition, the aluminium Securilight frame serves as a condensation drain tray to the outside.

1.8 To prevent ingress of moisture, the polycarbonate rooflights are fixed onto the upstand using the screws, Seala washers and caps supplied by the Certificate holder (see Figure 3).

1.9 Roof coverings are applied up to the external face of the upstand flange.

Design Data

2 Strength and stability

 2.1 Tests have shown that resistance to imposed snow loads and wind loads by the rooflights is dependent on size and configuration. As a guide, small pyramid-shaped rooflights are most resistant to imposed loads, whilst large, domed rooflights are the least resistant. Rooflights, therefore, should be selected according to the loads expected for a particular location. The results of tests for selected rooflights carried out generally in accordance with prEN 1873 : 2000, are given in Table 3.

Figure 3 Fixings

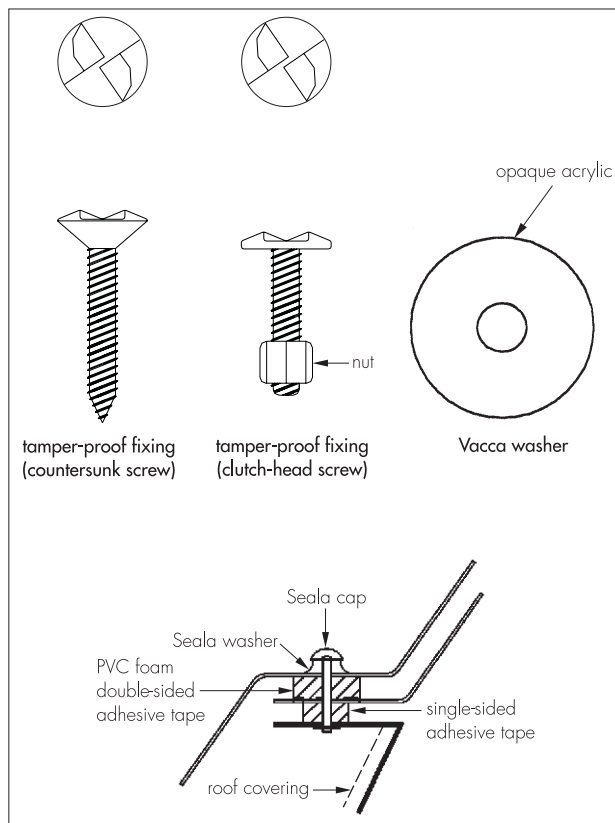

Figure 4 Securilight frame

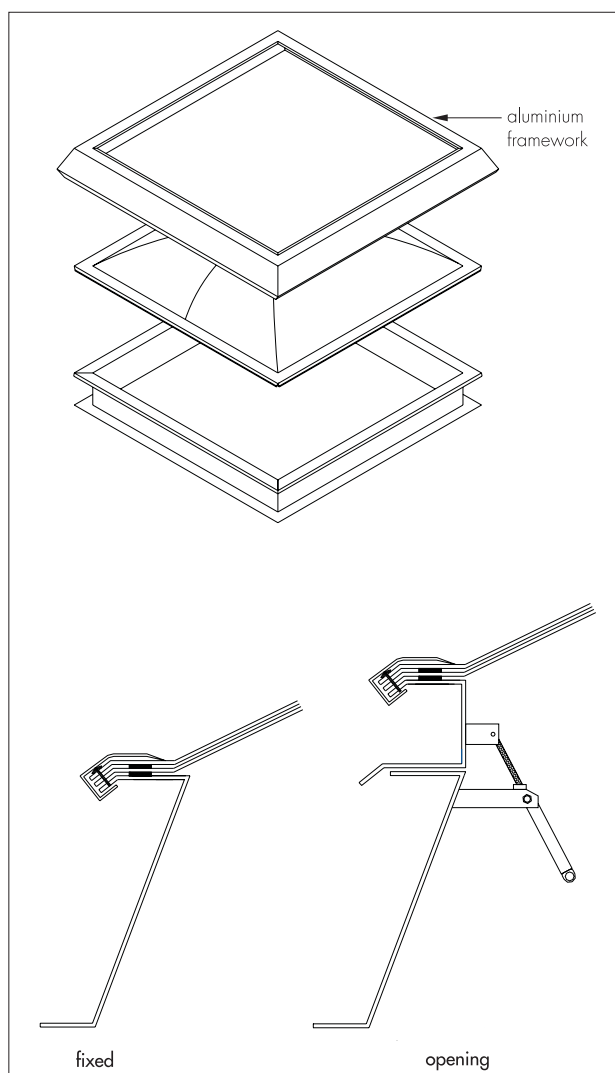

Table 3 Resistance to snow and wind loads

Rooflight type	Dimensions (mm)	Snow load (Nm ⁻²)	Wind load (Nm ⁻²)
Domed Securilight	1800 x 2400	DL750 ⁽¹⁾⁽²⁾	UL3000 ⁽³⁾

- (1) Downward load.
- (2) Buckling occurred at this load, but pressure applied internally restored the shape of the rooflight. Snow load was simulated by use of air pressure.
- (3) Upward load.

2.2 Fixing the rooflight to the upstand is described in section 6 of this Detail Sheet. Adequate resistance to wind uplift is achieved by this type of fixing.

2.3 The product has adequate resistance to soft-body impacts, such as a person accidentally falling against a rooflight. A dome rooflight measuring 1200 mm and a dome Securilight rooflight measuring 2400 mm by 1800 mm were classified as Class A and Class B, respectively, non-fragile assemblies to ACR(M) 001 : 2000.

3 Thermal properties

The thermal properties of upstands and opening frames are given in Table 4 and the derivation of the daylight and roof opening dimensions is shown in Figure 5. The U values given in Tables 5 to 10 are based on the internal surface area of the rooflights, and the information supplied can be used as input in the Simplified Building Energy Model (SBEM) to calculate the energy used by non-

domestic buildings. When required, for example in SAP calculations, the U values associated with the opening area in the roof can be calculated by multiplying the U value given in Tables 5 to 10 by the surface area ratio.

Table 4 Thermal properties of upstands and opening frames

Upstand ⁽¹⁾ type	Linear thermal transmittance (Wm ⁻¹ K ⁻¹)
Aluminium upstand ⁽²⁾	1.2
Aluminium upstand and opening frame ⁽²⁾	1.8
Galvanized steel upstand ⁽²⁾	1.1
Galvanized steel upstand and opening frame ⁽²⁾	1.6

- (1) Upstand 225 mm high with 10 mm thick cork insulation board and opening frame is 78 mm high.
- (2) The linear transmittance is unaffected by the addition of the Securilight frame.

Figure 5 Derivation of opening sizes

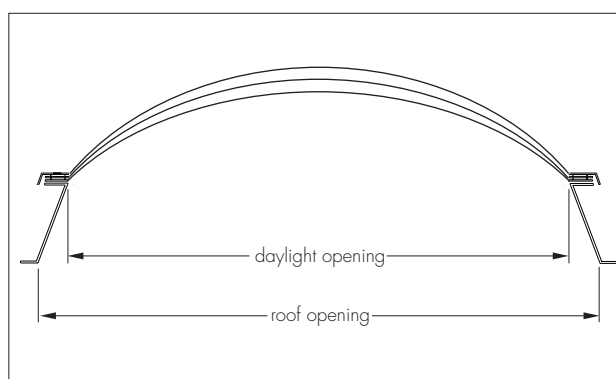

Table 5 Thermal transmittance (U values) of double- and triple-skin square dome rooflights with aluminium upstand

Width/length (m)	Daylight opening (m ²)	Roof opening (area projected) ⁽¹⁾ (m ²)	Surface area ratio ⁽¹⁾⁽²⁾	Rooflight U value — upstand (Wm ⁻² K ⁻¹)		Surface area ratio ⁽¹⁾⁽²⁾	Rooflight U value — upstand and opening frame (Wm ⁻² K ⁻¹)	
				Double-skin ⁽¹⁾⁽²⁾	Triple-skin ⁽¹⁾⁽²⁾		Double-skin ⁽¹⁾⁽²⁾	Triple-skin ⁽¹⁾⁽²⁾
0.60	0.36	0.60	1.9	4.2	3.7	2.2	4.7	4.3
0.75	0.56	0.85	1.8	4.1	3.6	2.1	4.6	4.1
0.90	0.81	1.15	1.7	4.0	3.4	2.0	4.5	4.0
1.00	1.00	1.37	1.7	4.0	3.3	1.9	4.4	3.9
1.05	1.10	1.49	1.6	3.9	3.3	1.9	4.4	3.8
1.20	1.44	1.88	1.6	3.9	3.2	1.8	4.3	3.7
1.35	1.82	2.32	1.6	3.8	3.1	1.8	4.2	3.6
1.50	2.25	2.80	1.5	3.8	3.0	1.7	4.2	3.5
1.65	2.72	3.32	1.5	3.7	3.0	1.7	4.1	3.4
1.80	3.24	3.89	1.5	3.7	2.9	1.7	4.0	3.3

- (1) SBEM input.
- (2) SAP input = rooflight U value multiplied by the surface area ratio (ie roof opening U value).

Table 6 Thermal transmittance (U values) of double- and triple-skin rooflights with aluminium upstand

Width (m)	Length (m)	Daylight opening (m ²)	Roof opening (area projected) ⁽¹⁾ (m ²)	Surface area ratio ⁽¹⁾⁽²⁾	Rooflight U value — upstand (Wm ⁻² K ⁻¹)		Surface area ratio ⁽¹⁾⁽²⁾	Rooflight U value — upstand and opening frame (Wm ⁻² K ⁻¹)	
					Double-skin ⁽¹⁾⁽²⁾	Triple-skin ⁽¹⁾⁽²⁾		Double-skin ⁽¹⁾⁽²⁾	Triple-skin ⁽¹⁾⁽²⁾
					0.60	0.90		0.54	0.83
0.60	1.20	0.72	1.06	1.7	4.1	3.5	2.0	4.6	4.1
0.60	1.50	0.90	1.29	1.7	4.0	3.5	1.9	4.5	4.1
0.60	1.80	1.08	1.52	1.6	4.0	3.5	1.9	4.5	4.0
0.60	2.40	1.44	1.99	1.6	4.0	3.4	1.9	4.5	4.0
0.90	1.20	1.08	1.47	1.6	4.0	3.3	1.9	4.4	3.9
0.90	1.35	1.22	1.63	1.6	3.9	3.3	1.8	4.4	3.8
0.90	1.50	1.35	1.79	1.6	3.9	3.3	1.8	4.4	3.8
0.90	1.80	1.62	2.11	1.5	3.9	3.2	1.8	4.3	3.8
0.90	2.40	2.16	2.76	1.5	3.9	3.2	1.7	4.3	3.7
1.00	1.50	1.50	1.96	1.6	3.9	3.2	1.8	4.3	3.7
1.00	2.00	2.00	2.55	1.5	3.8	3.2	1.7	4.3	3.7
1.20	1.50	1.80	2.29	1.5	3.8	3.1	1.7	4.2	3.6
1.20	1.80	2.16	2.71	1.5	3.8	3.1	1.7	4.2	3.6
1.20	2.40	2.88	3.53	1.5	3.8	3.0	1.6	4.2	3.5
1.50	2.40	3.60	4.30	1.4	3.7	2.9	1.5	4.1	3.4
1.80	2.40	4.32	5.07	1.4	3.7	2.9	1.5	4.0	3.3

(1) SBEM input.

(2) SAP input = rooflight U value multiplied by the surface area ratio (ie roof opening U value).

Table 7 Thermal transmittance (U values) of double- and triple-skin square pyramidal rooflights with aluminium upstand

Width/ length (m)	Daylight opening (m ²)	Roof opening (area projected) ⁽¹⁾ (m ²)	Surface area ratio ⁽¹⁾⁽²⁾	Rooflight U value — upstand (Wm ⁻² K ⁻¹)		Surface area ratio ⁽¹⁾⁽²⁾	Rooflight U value — upstand and opening frame (Wm ⁻² K ⁻¹)	
				Double-skin ⁽¹⁾⁽²⁾	Triple-skin ⁽¹⁾⁽²⁾		Double-skin ⁽¹⁾⁽²⁾	Triple-skin ⁽¹⁾⁽²⁾
				0.60	0.36		0.60	1.9
0.75	0.56	0.85	1.8	4.1	3.5	2.1	4.6	4.1
0.90	0.81	1.15	1.7	4.0	3.4	2.0	4.5	4.0
1.00	1.00	1.37	1.7	3.9	3.3	1.9	4.4	3.9
1.05	1.10	1.49	1.7	3.9	3.3	1.9	4.4	3.8
1.20	1.44	1.88	1.6	3.9	3.2	1.8	4.3	3.7
1.35	1.82	2.32	1.6	3.8	3.1	1.8	4.2	3.6
1.50	2.25	2.80	1.6	3.8	3.0	1.7	4.1	3.5
1.65	2.72	3.32	1.5	3.7	2.9	1.7	4.1	3.4
1.80	3.24	3.89	1.5	3.7	2.9	1.7	4.0	3.3

(1) SBEM input.

(2) SAP input = rooflight U value multiplied by the surface area ratio (ie roof opening U value).

Table 8 Thermal transmittance (U values) of double- and triple-skin square dome rooflights with galvanized steel upstand

Width/ length (m)	Daylight opening (m ²)	Roof opening (area projected) ⁽¹⁾ (m ²)	Surface area ratio ⁽¹⁾⁽²⁾	Rooflight U value — upstand (Wm ⁻² K ⁻¹)		Surface area ratio ⁽¹⁾⁽²⁾	Rooflight U value — upstand and opening frame (Wm ⁻² K ⁻¹)	
				Double-skin ⁽¹⁾⁽²⁾	Triple-skin ⁽¹⁾⁽²⁾		Double-skin ⁽¹⁾⁽²⁾	Triple-skin ⁽¹⁾⁽²⁾
				0.60	0.36		0.60	1.9
0.75	0.56	0.85	1.8	3.9	3.3	2.1	4.2	3.8
0.90	0.81	1.15	1.7	3.8	3.2	2.0	4.1	3.6
1.00	1.00	1.37	1.7	3.8	3.1	1.9	4.1	3.5
1.05	1.10	1.49	1.6	3.7	3.1	1.9	4.1	3.5
1.20	1.44	1.88	1.6	3.7	3.0	1.8	4.0	3.4
1.35	1.82	2.32	1.6	3.7	2.9	1.8	3.9	3.3
1.50	2.25	2.80	1.5	3.6	2.9	1.7	3.9	3.2
1.65	2.72	3.32	1.5	3.6	2.8	1.7	3.9	3.2
1.80	3.24	3.89	1.5	3.6	2.8	1.7	3.8	3.1

(1) SBEM input.

(2) SAP input = rooflight U value multiplied by the surface area ratio (ie roof opening U value).

Table 9 Thermal transmittance (U values) of double- and triple-skin rectangular dome rooflights with galvanized steel upstand

Width (m)	Length (m)	Daylight opening (m ²)	Roof opening (area projected) ⁽¹⁾ (m ²)	Surface area ratio ⁽¹⁾⁽²⁾	Rooflight U value — upstand (Wm ⁻² K ⁻¹)		Surface area ratio ⁽¹⁾⁽²⁾	Rooflight U value — upstand and opening frame (Wm ⁻² K ⁻¹)	
					Double-skin ⁽¹⁾⁽²⁾	Triple-skin ⁽¹⁾⁽²⁾		Double-skin ⁽¹⁾⁽²⁾	Triple-skin ⁽¹⁾⁽²⁾
0.60	0.90	0.54	0.83	1.8	3.9	3.4	2.1	4.2	3.8
0.60	1.20	0.72	1.06	1.7	3.9	3.3	2.0	4.2	3.8
0.60	1.50	0.90	1.29	1.7	3.8	3.3	1.9	4.2	3.7
0.60	1.80	1.08	1.52	1.6	3.8	3.2	1.9	4.2	3.7
0.60	2.40	1.44	1.99	1.6	3.8	3.2	1.9	4.1	3.6
0.90	1.20	1.08	1.47	1.6	3.8	3.1	1.9	4.1	3.5
0.90	1.35	1.22	1.63	1.6	3.7	3.1	1.8	4.1	3.5
0.90	1.50	1.35	1.79	1.6	3.7	3.1	1.8	4.0	3.5
0.90	1.80	1.62	2.11	1.5	3.7	3.1	1.8	4.0	3.4
0.90	2.40	2.16	2.76	1.5	3.7	3.0	1.7	4.0	3.4
1.00	1.50	1.50	1.96	1.6	3.7	3.0	1.8	4.0	3.4
1.00	2.00	2.00	2.55	1.5	3.7	3.0	1.7	4.0	3.4
1.20	1.50	1.80	2.29	1.5	3.7	3.0	1.7	4.0	3.3
1.20	1.80	2.16	2.71	1.5	3.7	2.9	1.7	3.9	3.3
1.20	2.40	2.88	3.53	1.5	3.6	2.9	1.6	3.9	3.2
1.50	2.40	3.60	4.30	1.4	3.6	2.8	1.5	3.8	3.1
1.80	2.40	4.32	5.07	1.4	3.6	2.8	1.5	3.8	3.1

(1) SBEM input.

(2) SAP input = rooflight U value multiplied by the surface area ratio (ie roof opening U value).

Table 10 Thermal transmittance (U values) of double- and triple-skin square pyramidal rooflights with galvanized steel upstands

Width/ length (m)	Daylight opening (m ²)	Roof opening (area projected) ⁽¹⁾ (m ²)	Surface area ratio ⁽¹⁾⁽²⁾	Rooflight U value — upstand (Wm ⁻² K ⁻¹)		Surface area ratio ⁽¹⁾⁽²⁾	Rooflight U value — upstand and opening frame (Wm ⁻² K ⁻¹)	
				Double-skin ⁽¹⁾⁽²⁾	Triple-skin ⁽¹⁾⁽²⁾		Double-skin ⁽¹⁾⁽²⁾	Triple-skin ⁽¹⁾⁽²⁾
0.60	0.36	0.60	1.9	3.9	3.5	2.3	4.3	3.9
0.75	0.56	0.85	1.8	3.9	3.3	2.1	4.2	3.8
0.90	0.81	1.15	1.7	3.8	3.2	2.0	4.1	3.6
1.00	1.00	1.37	1.7	3.8	3.1	1.9	4.1	3.5
1.05	1.10	1.49	1.7	3.7	3.1	1.9	4.1	3.5
1.20	1.44	1.88	1.6	3.7	3.0	1.8	4.0	3.4
1.35	1.82	2.32	1.6	3.7	2.9	1.8	3.9	3.3
1.50	2.25	2.80	1.6	3.6	2.9	1.7	3.9	3.2
1.65	2.72	3.32	1.5	3.6	2.8	1.7	3.8	3.1
1.80	3.24	3.89	1.5	3.6	2.8	1.7	3.8	3.1

(1) SBEM input.

(2) SAP input = rooflight U value multiplied by the surface area ratio (ie roof opening U value).

4 Security against intrusion

4.1 The rooflights are supplied with tamper-proof fixings (clutch-head screws), unless otherwise specified, to make removal of the rooflight from the upstand more difficult (see Figure 3).

4.2 Polycarbonate rooflights have a good resistance to impact, making breakage very difficult.

4.3 The rooflights can be specified with a SecuriLight frame (a welded-aluminium framework) around the edge of the rooflight, thus providing a continuous concealed fixing between rooflight and upstand.

Installation

5 General

5.1 Installation of The NaturalLight Fixed or Opening Individual Rooflights and Upstands must be carried out in accordance with the Certificate holder's installation instructions.

5.2 Prior to installation of the rooflight, the roof must be checked by means of calculations or testing to ensure that it can carry the additional loads the installation may impose, strengthening the roof if necessary. This work must be carried out by a suitably-qualified person.

5.3 The rooflight upstand should be checked dimensionally to ensure the fit, and the rooflight should be checked for size before the unit is lifted to the roof.

5.4 A rooflight should never be left in position without ensuring all its fixings are present and fully tightened.

5.5 Where the roof covering is dressed below the rooflight and on top of a timber or concrete upstand, precautions should be taken to prevent bitumen damaging internal finishes.

5.6 Fixings for fixing the upstands or adaptor upstands onto the roof structure are not supplied by the Certificate holder. However, it is recommended to fix 90 mm to 100 mm from corners and at 250 mm to 300 mm centres.

6 Procedure

Fixing NaturalLight rooflights to NaturalLight galvanized steel or aluminium upstands

6.1 The plastic rooflight is placed on the upstand and the positions of the holes on the rooflight are marked onto the upstand. Holes (8 mm diameter) are drilled through at those points, ensuring that the swarf is removed from the upstand after drilling.

6.2 Double- and triple-skin rooflights are provided with a loose roll of single-sided adhesive tape which is to be fitted between the rooflight and the upstand. The protective paper is peeled off and the adhesive face is placed on the upstand, taking care not to stretch the tape. The tape should be mitred at corners. The PVC Seala washer is positioned on the rooflight and the bolt is fitted through the hole, the nut attached and the bolt tightened; then the PVC Seala cap is fitted. Trickle washers can be specified on request as an alternative to tape, where background ventilation is required.

Technical Investigations

The following is a summary of the technical investigations carried out on The NaturalLight Fixed or Opening Individual Rooflights and Upstands.

7 Tests

Tests were carried out in accordance with prEN 1873 : 2000 to determine:

- watertightness
- effect of wind loads
- effect of snow loads
- effect of impact
- suitability of materials.

8 Investigations

8.1 The manufacturing process was examined, including the methods adopted for quality control, and details were obtained relating to the quality and composition of the materials.

8.2 Computer calculations for assessing the risk of condensation and calculating the thermal transmittance of the rooflights were carried out.

8.3 Existing data were examined in relation to performance in fire.

8.4 Components were assessed for resistance to corrosion.

Bibliography

prEN 1873 : 2000 *Roof coverings — Individual rooflights of plastics with upstands*

Advisory Committee for Roofwork, ACR[M]001 : 2000 *Test For Fragility of Roofing Assemblies* [second edition]



On behalf of the British Board of Agrément

A handwritten signature in black ink, appearing to read 'G. A. Cooper'.

Date of issue: 21st November 2007

Chief Executive

Product

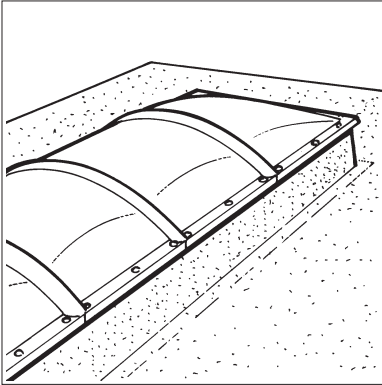

- THIS DETAIL SHEET RELATES TO THE NATURALIGHT FIXED CONTINUOUS BARREL VAULT ROOFLIGHTS AND UPSTANDS.

This Detail Sheet must be read in conjunction with the Front Sheets, which give the product's position regarding the Building Regulations, general information relating to the system, and the Conditions of Certification.

Technical Specification

1 Description

1.1 The skins of The NaturalLight Fixed Continuous Barrel Vault polycarbonate Rooflights are designed and thermoformed from 3 mm minimum thick polycarbonate sheets with both sides coated with UV protection film for use in the exposure conditions described in this Detail Sheet. They are available in interlocking sections of one metre maximum nominal width to form continuous runs with thermoformed jointing pieces. Domed ends vary to allow for non-modular lengths.

1.2 The polycarbonate rooflights are available as double- or triple-skin, in clear smooth finish and are fixed through factory-drilled holes onto the upstands. Double- and triple-skin rooflights incorporate a double-sided adhesive PVC foam tape between skins. They are available in section in the sizes listed in Table 1 and shown in Figure 1.

1.3 Other sizes within this size range can also be fabricated on request and are covered by this Detail Sheet with both sides coated with UV

protection film for use in the exposure conditions described in this Detail Sheet.

1.4 The upstands are available in two materials: galvanized steel and aluminium. The galvanized steel and aluminium upstands have a white powder-coated finish is available as an option. Holes for fixing the upstands onto the roof structure are drilled on site. The types of upstands are listed in Table 2 and shown in Figure 2.

Table 1 Sizes of barrel vault rooflights

Width (mm)	Length (mm)
600	as required in 1 m sections
750	
900	
1050	
1200	
1350	
1500	
1650	
1800	
1950	
2100	
2250	
2400	

Figure 1 NaturalLight barrel vault rooflights



Table 2 NaturalLight upstands

Type	Upstands for barrel vault rooflights
Unvented	NLS 300
Permanent ventilation	NLS 310
Hit-and-miss	NLS 320
Hit-and-miss slimline	NLS 325
Controlled louvre	NLS 330
Controlled louvre 50%	NLS 360
Adaptor upstand ⁽¹⁾	—

(1) Available in galvanized steel and aluminium.

1.5 Cork insulation (10 mm thick) is available for aluminium and galvanized steel upstands.

1.6 Upstands may be unvented or may incorporate permanent vents, hit-and-miss vents or

controlled louvres (see Table 2 and Figure 2). The height of galvanized steel and aluminium unvented upstands is 225 mm and that of the vented types 225 mm to the underside of the vent. Additional height can be provided to metal upstands to compensate for fitting below deck, or exceptional depth of insulation and screed.

1.7 The full specifications and drawings for the materials and components covered by this Detail Sheet are retained by the BBA.

1.8 To prevent the ingress of moisture, the polycarbonate rooflights are fixed onto the upstand using the screws, Seala washers and caps supplied by the Certificate holder (see Figure 3).

1.9 Roof coverings are applied up to the external face of the upstand flange.

Figure 2 Typical NaturalLight upstands

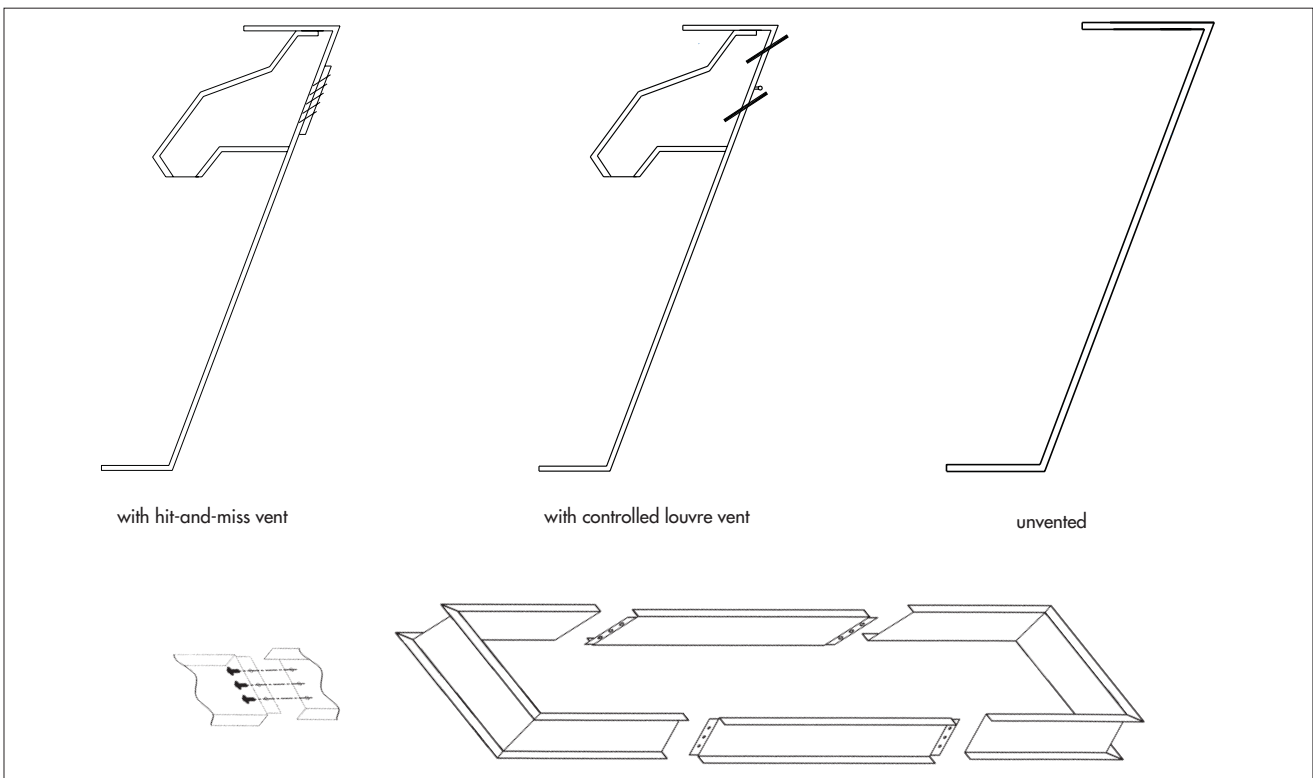
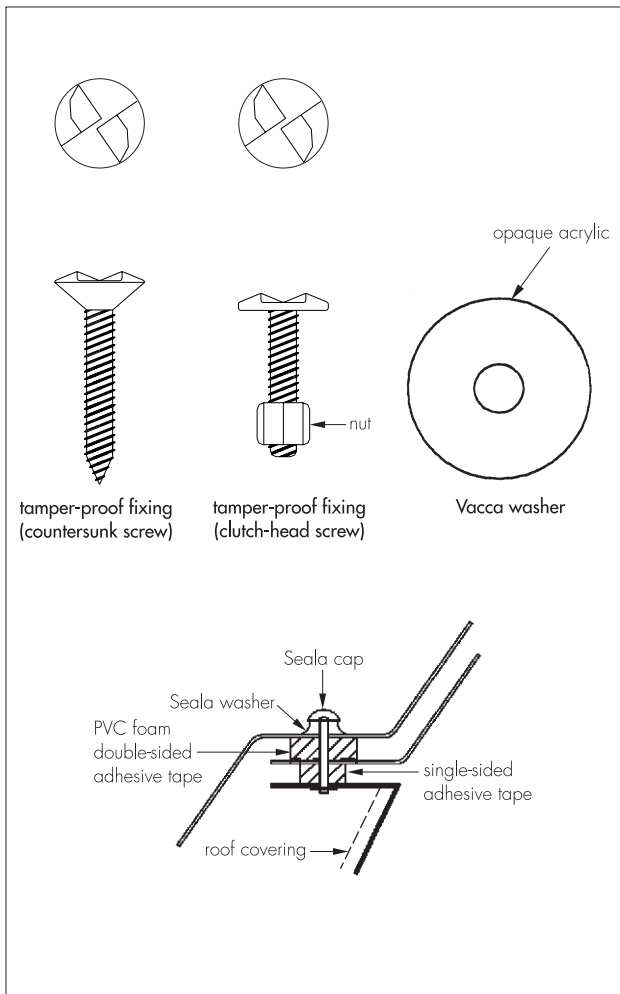

Figure 3 Fixings



Design Data

2 Structural stability

2.1 Tests were carried out on a barrel vault rooflight 2400 mm wide by 3000 mm long, comprising three sections. Snow loading was simulated by use of air pressure. The results of tests carried out generally in accordance with prEN 1873 : 2000 are given in Table 3.

Table 3 Resistance to snow loads

Rooflight size	Snow load (Nm ⁻²)
2400 mm x 3000 mm	DL 750 ⁽¹⁾

(1) Downward load.

2.2 Fixing the barrel vault rooflight to the upstand is described in section 6 of this Detail Sheet. Adequate resistance to wind uplift is achieved by this type of fixing.

2.3 The product has adequate resistance to soft-body impacts, such as a person accidentally falling against a rooflight. A barrel vault rooflight measuring 2750 mm by 2100 mm (internal dimensions) was classified as a Class B non-fragile assembly to ACR(M) 001 : 2000.

3 Thermal properties

The thermal properties of the upstands are given in Table 4 and the derivation of the daylight and roof opening dimensions are shown in Figure 4. The U values given in Tables 5 and 6 are based on the internal surface area of the rooflights, and the information supplied can be used as input in the Simplified Building Energy Model (SBEM) to calculate the energy used by non-domestic buildings. When required, for example in SAP calculations, the U values associated with the opening area in the roof can be calculated by multiplying the U value given in Tables 5 and 6 by the surface area ratio.

Table 4 Thermal properties of upstands

Upstand ⁽¹⁾ type	Linear thermal transmittance (Wm ⁻¹ K ⁻¹)
Aluminium upstand	1.2
Galvanized steel upstand	1.1

(1) Upstand is 225 mm high with 10 mm thick cork insulation board.

Figure 4 Derivation of opening sizes

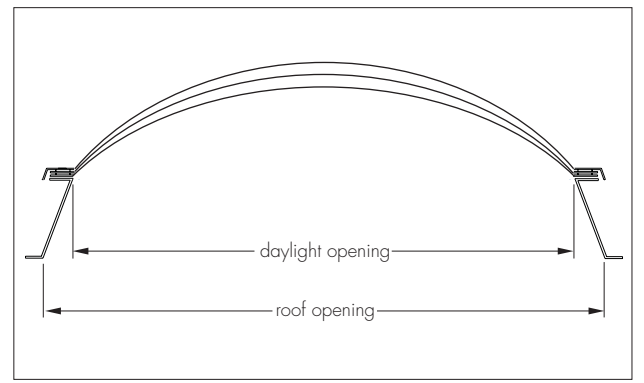

4 Security against intrusion

4.1 The rooflights are supplied with tamper-proof fixings (clutch-head screws), unless otherwise specified, to make removal of the rooflight from the upstand more difficult (see Figure 3).

4.2 Polycarbonate rooflights have a good resistance to impact, making breakage very difficult.

Table 5 Thermal transmittance (U values) of double- and triple-skin barrel vault rooflights with aluminium upstand

Width (m)	Length (m)	Daylight opening (m ²)	Surface area ratio ⁽¹⁾⁽²⁾	Roof opening (area projected) ⁽¹⁾ (m ²)	Surface area ratio ⁽¹⁾⁽²⁾	Rooflight U value – upstand (Wm ⁻² K ⁻¹)	
						Double-skin ⁽¹⁾⁽²⁾	Triple-skin ⁽¹⁾⁽²⁾
0.60	2.00	1.20	1.9	1.68	2.2	3.9	3.2
0.60	3.00	1.80	1.9	2.45	2.1	3.8	3.2
0.60	4.00	2.40	1.8	3.22	2.1	3.8	3.1
0.60	5.00	3.00	1.8	3.99	2.0	3.8	3.1
0.60	6.00	3.60	1.8	4.76	2.0	3.8	3.1
0.75	2.00	1.50	1.8	2.00	2.0	3.8	3.1
0.75	3.00	2.25	1.7	2.92	1.9	3.8	3.1
0.75	4.00	3.00	1.7	3.85	1.9	3.8	3.1
0.75	5.00	3.75	1.7	4.77	1.9	3.8	3.0
0.75	6.00	4.50	1.6	5.69	1.8	3.8	3.0
0.90	2.00	1.80	1.7	2.33	1.9	3.8	3.1
0.90	3.00	2.70	1.6	3.40	1.8	3.8	3.0
0.90	4.00	3.60	1.6	4.47	1.8	3.8	3.0
0.90	5.00	4.50	1.6	5.54	1.7	3.7	3.0
0.90	6.00	5.40	1.5	6.62	1.7	3.7	3.0
1.05	2.00	2.10	1.6	2.65	1.8	3.8	3.0
1.05	3.00	3.15	1.6	3.88	1.7	3.7	3.0
1.05	4.00	4.20	1.5	5.10	1.7	3.7	2.9
1.05	5.00	5.25	1.5	6.32	1.6	3.7	2.9
1.05	6.00	6.30	1.5	7.54	1.6	3.7	2.9
1.20	2.00	2.40	1.6	2.98	1.8	3.8	3.0
1.20	3.00	3.60	1.5	4.35	1.7	3.7	2.9
1.20	4.00	4.80	1.5	5.72	1.6	3.7	2.9
1.20	5.00	6.00	1.4	7.10	1.6	3.7	2.9
1.20	6.00	7.20	1.4	8.47	1.6	3.7	2.9
1.35	2.00	2.70	1.5	3.31	1.7	3.7	3.0
1.35	3.00	4.05	1.5	4.83	1.6	3.7	2.9
1.35	4.00	5.40	1.4	6.35	1.6	3.7	2.8
1.35	5.00	6.75	1.4	7.87	1.5	3.7	2.8
1.35	6.00	8.10	1.4	9.39	1.5	3.6	2.8
1.50	2.00	3.00	1.5	3.63	1.7	3.7	2.9
1.50	3.00	4.50	1.4	5.30	1.6	3.7	2.9
1.50	4.00	6.00	1.4	6.98	1.5	3.6	2.8
1.50	5.00	7.50	1.4	8.65	1.5	3.6	2.8
1.50	6.00	9.00	1.3	10.32	1.5	3.6	2.8
1.65	2.00	3.30	1.5	3.96	1.7	3.7	2.9
1.65	3.00	4.95	1.4	5.78	1.5	3.6	2.8
1.65	4.00	6.60	1.4	7.60	1.5	3.6	2.8
1.65	5.00	8.25	1.3	9.42	1.5	3.6	2.7
1.65	6.00	9.90	1.3	11.25	1.4	3.6	2.7
1.80	2.00	3.60	1.7	4.28	1.8	3.6	2.8
1.80	3.00	5.40	1.6	6.26	1.7	3.6	2.7
1.80	4.00	7.20	1.5	8.23	1.6	3.6	2.7
1.80	5.00	9.00	1.5	10.20	1.6	3.5	2.6
1.80	6.00	10.80	1.4	12.17	1.6	3.5	2.6
1.95	2.00	3.90	1.7	4.61	1.8	3.6	2.7
1.95	3.00	5.85	1.5	6.73	1.7	3.6	2.7
1.95	4.00	7.80	1.5	8.85	1.6	3.5	2.6
1.95	5.00	9.75	1.4	10.97	1.6	3.5	2.6
1.95	6.00	11.70	1.4	13.10	1.5	3.5	2.6
2.10	2.00	4.20	1.7	4.93	1.9	3.6	2.7
2.10	3.00	6.30	1.6	7.21	1.7	3.5	2.6
2.10	4.00	8.40	1.5	9.48	1.6	3.5	2.6
2.10	5.00	10.50	1.5	11.75	1.6	3.5	2.6
2.10	6.00	12.60	1.4	14.02	1.5	3.5	2.6
2.25	2.00	4.50	1.7	5.26	1.9	3.6	2.7
2.25	3.00	6.75	1.6	7.68	1.7	3.5	2.6
2.25	4.00	9.00	1.5	10.10	1.6	3.5	2.6
2.25	5.00	11.25	1.5	12.53	1.6	3.5	2.6
2.25	6.00	13.50	1.4	14.95	1.5	3.5	2.5
2.40	2.00	4.80	1.8	5.59	1.9	3.5	2.6
2.40	3.00	7.20	1.6	8.16	1.7	3.5	2.6
2.40	4.00	9.60	1.5	10.73	1.6	3.5	2.5
2.40	5.00	12.00	1.5	13.30	1.6	3.5	2.5
2.40	6.00	14.40	1.4	15.87	1.5	3.5	2.5

(1) SBEM input.

(2) SAP input = rooflight U value multiplied by the surface area ratio (ie roof opening U value).

Table 6 Thermal transmittance (U values) of double- and triple-skin barrel vault rooflights with galvanized steel upstand

Width (m)	Length (m)	Daylight opening (m ²)	Surface area ratio ⁽¹⁾⁽²⁾	Roof opening (area projected) ⁽¹⁾ (m ²)	Surface area ratio ⁽¹⁾⁽²⁾	Rooflight U value – upstand (Wm ⁻² K ⁻¹)	
						Doubleskin ⁽¹⁾⁽²⁾	Triple-skin ⁽¹⁾⁽²⁾
0.60	2.00	1.20	1.9	1.68	2.2	3.7	3.0
0.60	3.00	1.80	1.9	2.45	2.1	3.0	2.1
0.60	4.00	2.40	1.8	3.22	2.1	3.0	2.1
0.60	5.00	3.00	1.8	3.99	2.0	3.0	2.0
0.60	6.00	3.60	1.8	4.76	2.0	3.7	2.9
0.75	2.00	1.50	1.8	2.00	2.0	3.7	3.0
0.75	3.00	2.25	1.7	2.92	1.9	3.7	2.9
0.75	4.00	3.00	1.7	3.85	1.9	3.6	2.9
0.75	5.00	3.75	1.7	4.77	1.9	3.6	2.9
0.75	6.00	4.50	1.6	5.69	1.8	3.6	2.9
0.90	2.00	1.80	1.7	2.33	1.9	3.6	2.9
0.90	3.00	2.70	1.6	3.40	1.8	3.6	2.9
0.90	4.00	3.60	1.6	4.47	1.8	3.6	2.9
0.90	5.00	4.50	1.6	5.54	1.7	3.6	2.8
0.90	6.00	5.40	1.5	6.62	1.7	3.6	2.8
1.05	2.00	2.10	1.6	2.65	1.8	3.6	2.9
1.05	3.00	3.15	1.6	3.88	1.7	3.6	2.8
1.05	4.00	4.20	1.5	5.10	1.7	3.6	2.8
1.05	5.00	5.25	1.5	6.32	1.6	3.6	2.8
1.05	6.00	6.30	1.5	7.54	1.6	3.6	2.8
1.20	2.00	2.40	1.6	2.98	1.8	3.6	2.9
1.20	3.00	3.60	1.5	4.35	1.7	3.6	2.8
1.20	4.00	4.80	1.5	5.72	1.6	3.6	2.8
1.20	5.00	6.00	1.4	7.10	1.6	3.6	2.7
1.20	6.00	7.20	1.4	8.47	1.6	3.5	2.7
1.35	2.00	2.70	1.5	3.31	1.7	3.6	2.8
1.35	3.00	4.05	1.5	4.83	1.6	3.6	2.8
1.35	4.00	5.40	1.4	6.35	1.6	3.5	2.7
1.35	5.00	6.75	1.4	7.87	1.5	3.5	2.7
1.35	6.00	8.10	1.4	9.39	1.5	3.5	2.7
1.50	2.00	3.00	1.5	3.63	1.7	3.6	2.8
1.50	3.00	4.50	1.4	5.30	1.6	3.5	2.7
1.50	4.00	6.00	1.4	6.98	1.5	3.5	2.7
1.50	5.00	7.50	1.4	8.65	1.5	3.5	2.7
1.50	6.00	9.00	1.3	10.32	1.5	3.5	2.7
1.65	2.00	3.30	1.5	3.96	1.7	3.6	2.8
1.65	3.00	4.95	1.4	5.78	1.5	3.5	2.7
1.65	4.00	6.60	1.4	7.60	1.5	3.5	2.7
1.65	5.00	8.25	1.3	9.42	1.5	3.5	2.6
1.65	6.00	9.90	1.3	11.25	1.4	3.5	2.6
1.80	2.00	3.60	1.7	4.28	1.8	3.5	2.6
1.80	3.00	5.40	1.6	6.26	1.7	3.5	2.6
1.80	4.00	7.20	1.5	8.23	1.6	3.5	2.6
1.80	5.00	9.00	1.5	10.20	1.6	3.4	2.5
1.80	6.00	10.80	1.4	12.17	1.6	3.4	2.5
1.95	2.00	3.90	1.7	4.61	1.8	3.5	2.6
1.95	3.00	5.85	1.5	6.73	1.7	3.5	2.6
1.95	4.00	7.80	1.5	8.85	1.6	3.4	2.5
1.95	5.00	9.75	1.4	10.97	1.6	3.4	2.5
1.95	6.00	11.70	1.4	13.10	1.5	3.4	2.5
2.10	2.00	4.20	1.7	4.93	1.9	3.5	2.6
2.10	3.00	6.30	1.6	7.21	1.7	3.4	2.5
2.10	4.00	8.40	1.5	9.48	1.6	3.4	2.5
2.10	5.00	10.50	1.5	11.75	1.6	3.4	2.5
2.10	6.00	12.60	1.4	14.02	1.5	3.4	2.5
2.25	2.00	4.50	1.7	5.26	1.9	3.5	2.6
2.25	3.00	6.75	1.6	7.68	1.7	3.4	2.5
2.25	4.00	9.00	1.5	10.10	1.6	3.4	2.5
2.25	5.00	11.25	1.5	12.53	1.6	3.4	2.5
2.25	6.00	13.50	1.4	14.95	1.5	3.4	2.5
2.40	2.00	4.80	1.8	5.59	1.9	3.4	2.5
2.40	3.00	7.20	1.6	8.16	1.7	3.4	2.5
2.40	4.00	9.60	1.5	10.73	1.6	3.4	2.5
2.40	5.00	12.00	1.5	13.30	1.6	3.4	2.4
2.40	6.00	14.40	1.4	15.87	1.5	3.4	2.4

(1) SBEM input.

(2) SAP input = rooflight U value multiplied by the surface area ratio (ie roof opening U value).

Installation

5 General

5.1 Installation of the NaturalLight Fixed Continuous Barrel Vault Rooflights and Upstands must be carried out in accordance with the Certificate holder's installation instructions.

5.2 Prior to installation of the rooflight, the roof must be checked by means of calculations or testing to ensure that it can carry the additional loads the installation may impose, strengthening the roof if necessary. This work must be carried out by a suitably-qualified person.

5.3 The rooflight upstand should be checked dimensionally to ensure the fit; and the rooflight should be checked for size before the unit is lifted to the roof.

5.4 Individual barrel vault units are dry joined together, as shown in Figure 1.

5.5 A rooflight should never be left in position without ensuring all its fixings are present and fully tightened.

5.6 Fixings for fixing NaturalLight upstands or adaptor upstands onto the roof structure are not supplied by the Certificate holder.

6 Procedure

Fixing NaturalLight rooflights to NaturalLight galvanized steel or aluminium upstands (see Figure 5)

6.1 Rooflights are provided with a loose roll of single-sided adhesive tape which is to be fitted between the rooflight and the upstand. The protective paper is peeled off and the adhesive face is placed on the upstand, taking care not to stretch the tape. The tape should be mitred at corners and butt jointed.

6.2 The left-hand end of the barrel vault rooflight is temporarily placed onto the upstand, followed by the centre section, ensuring that the small roll lap is always on the right-hand side. The temporary positioning of the rooflight is completed by adding the last end section.

6.3 Starting from the right-hand side of the rooflight, holes (8 mm) are drilled through the upstand at positions marked '1' (see Figure 5) progressing to the left-hand side of the rooflight. Seal washers are positioned on the rooflight and bolts fitted through the holes, nuts attached and the bolts tightened, prior to the Seala caps being fitted.

6.4 Again starting from the right-hand side, the end section C is pushed horizontally towards the fixed side of the rooflight and the rooflight is fixed at positions marked '2'. Centre sections B are fixed in the same way (from the right to the left) at positions marked '3'. Finally, the end section A is fixed at positions marked '4'.

6.5 Trickle washers can be specified on request as an alternative to the single-sided adhesive tape, where background ventilation is required.

Figure 5 Typical installation details

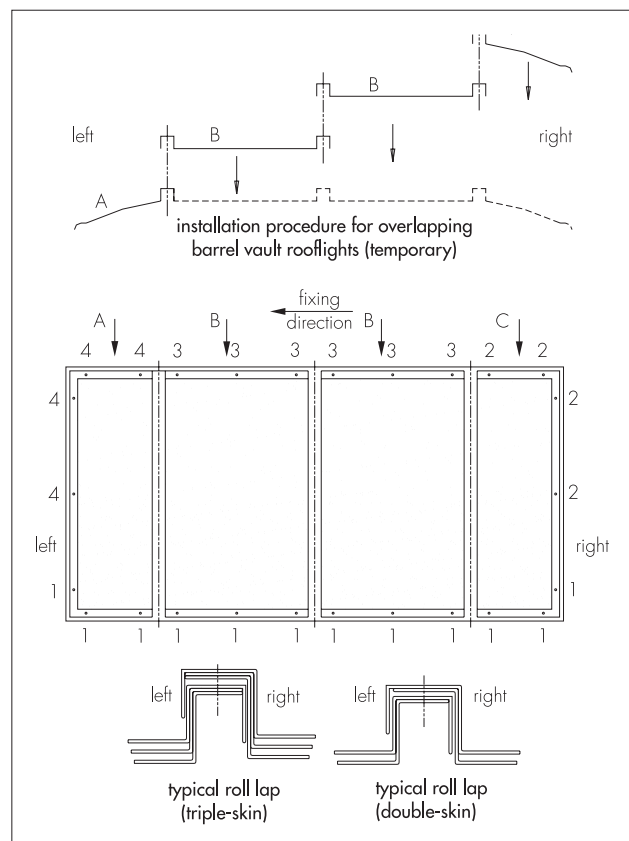

Technical Investigations

The following is a summary of the technical investigations carried out on The NaturalLight Fixed Continuous Barrel Vault Rooflights and Upstands.

7 Tests

Tests were carried out in accordance with prEN 1873 : 2000 to determine:

- watertightness
- effect of snow loads
- effect of impact
- suitability of materials.

8 Investigations

8.1 The manufacturing process was examined, including the methods adopted for quality control, and details were obtained relating to the quality and composition of the materials.

8.2 Computer calculations for assessing the risk of condensation and calculating the thermal transmittance of the rooflights were carried out.

8.3 An examination was made of existing data in relation to performance in fire and suitability of materials.

8.4 Components were assessed for resistance to corrosion.

Bibliography

prEN 1873 : 2000 *Roof coverings — Individual rooflights of plastic with upstands*

Advisory Committee for Roofwork, ACR[M]001 :
2000 *Test For Fragility of Roofing Assemblies*
[second edition]



On behalf of the British Board of Agrément

Date of issue: 21st November 2007



Chief Executive

